

Operating Temperature:

-55°C to +125°C

Operating Voltage:

50 VDC, 100 VDC, 200 VDC, 125 VAC, 400Hz

Rated Current:

10 Amperes maximum

Dielectric Strength:

Twice DC Operating Voltage @ +25°C, 50 mA maximum charging current.

Insulation Resistance:

Measured with rated DC voltage, 100 megohm-microfarad or 100,000 megohms minimum, whichever is less, 50 mA maximum charging current, @ +25 after two minutes.

Insertion Loss:

At -55°C to +125°C, the insertion loss will decrease a maximum of 3 dB from the +25°C value.

Military Specifications:

Meets or exceeds the applicable parameters of MIL-PRF-15733 and MIL-PRF-28861.

Housing (Non Hermetically Sealed) and Hardware:

Electro-tin-lead plated or hot solder dipped, and can be supplied with silver or high purity gold plating.

Marking:

LOGO	PART NUMBER			DATE CODE	
W	CF	XX	XX	XX	XX

12-32 Thread Epoxy Sealed (AC/DC Applications)

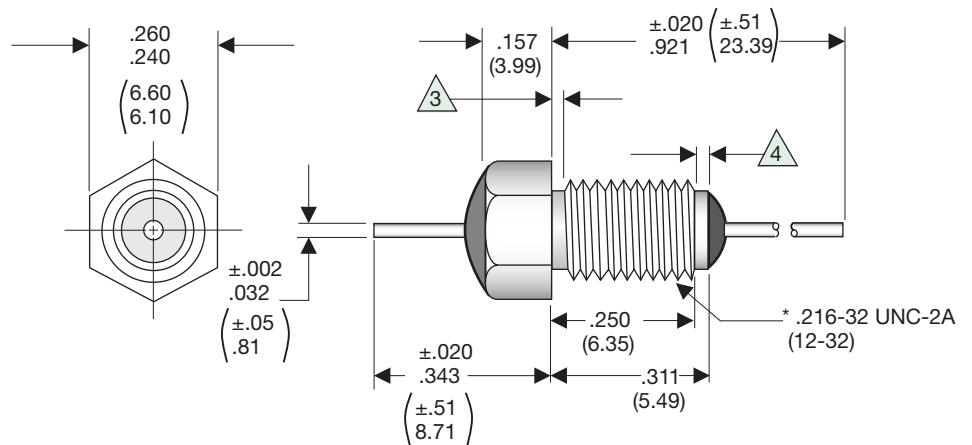

Notes:

1. Dimensions are inches (mm in parantheses).
2. *All units supplied with internal tooth lockwasher and hex nut, dimensions on page 6.
3. Imperfect thread or .040 inch maximum undercut optional.
4. One imperfect thread allowed, .040 inches maximum.
5. Recommended mounting torque 68 oz-in maximum.
6. Potting shall not extend beyond .030 inches from body.
7. Tolerance: $\pm .010$ ($\pm .254$ mm) unless otherwise specified.
8. Alternate capacitance values and various mechanical configurations available upon request.

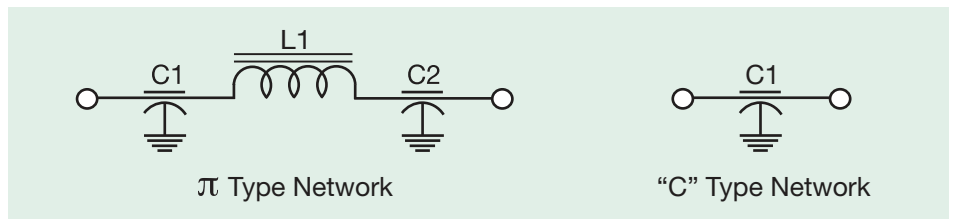

PART NUMBER	CAPACITANCE μF +100%, - 0%	CIRCUIT	WORKING VOLTAGE		MINIMUM INSERTION LOSS (Db) At +25°C IN ACCORDANCE WITH MIL-STD-220 ^{1,2}					
			DC VOLTS	AC 400 HZ	1 MHz	10 MHz	100 MHz	200 MHz	1 GHz	10 GHz
CF 9-001	0.015	π	50		23	40	60	70	70	70
CF 9-005	0.010	π	100		10	40	70	70	70	70
CF 9-010	0.012	π	200		-	16	65	65	70	70
CF 9-002	0.300	C	50		29	40	55	60	70	70
CF 9-003	0.050	C	100		15	35	42	50	70	70
CF 9-004	0.100	C	100		20	38	48	53	70	70
CF 9-006	0.150	C	100		23	39	50	55	70	70
CF 9-007	1000 pF	C	200	115	-	4	20	25	40	50
CF 9-008	5000 pF	C	200	115	-	15	34	41	45	50
CF 9-009	0.010	C	200	115	4	21	35	42	55	60
CF 9-011	0.027	C	200	115	10	30	39	45	65	70

1 Insertion loss measurements shall be made under full load over the frequency range of 1.0 MHz to 10 MHz. Insertion loss measurements above this frequency range under no load.
2 The insertion loss requirements between any two adjacent specified frequencies shall be that of the lower of the two frequencies in order to accommodate resonant dips.